

SMART MULTIMODAL THERAPEUTIC BRACE FOR POSTURE CORRECTION

Mr. DENNY A FRANKLIN JOSHUA

Dept of Biomedical Engineering Assistant Professor
Sri Shakthi Institute of Engineering and Technology, Coimbatore, India
dennyfranklin27@gmail.com

Ms. FATHIMA ISHARA N

Dept of Biomedical Engineering IV Year UG Student
Sri Shakthi Institute of Engineering and Technology, Coimbatore, India
isharanalakath2004@gmail.com

Ms. DHANYA R

Dept of Biomedical Engineering IV Year UG Student
Sri Shakthi Institute of Engineering and Technology, Coimbatore, India
dhanya20457@gmail.com

Mr. SAHEER MOHAMMED AK.

Dept of Biomedical Engineering IV Year UG Student
Sri Shakthi Institute of Engineering and Technology, Coimbatore, India
saheer7127@gmail.com

Ms. DHARSHANA M

Dept of Biomedical Engineering IV Year UG Student
Sri Shakthi Institute of Engineering and Technology, Coimbatore, India
dharshanamurugan04@gmail.com

Abstract

This paper presents the design and development of a smart wearable therapeutic brace for real-time posture correction and spinal support. The system integrates motion sensors, pressure sensors, and an embedded microcontroller to continuously monitor spinal alignment and detect posture deviations. A closed-loop feedback mechanism using graded vibration alerts enables immediate corrective action while maintaining user comfort. Wireless connectivity allows posture data to be viewed through a mobile interface for long-term monitoring and rehabilitation assessment. Prototype evaluation conducted on volunteers demonstrated reliable posture detection, responsive feedback, and comfortable wearability during daily activities. The proposed system provides a non-invasive, portable, and cost-effective solution for posture rehabilitation and preventive spinal care.

Keywords: *Posture correction, wearable rehabilitation, spinal monitoring, biofeedback system, assistive biomedical device.*

1. Introduction

Spinal health plays a crucial role in maintaining mobility, stability, and overall quality of life. Disorders of the spine, including scoliosis, kyphosis, spondylosis, and posture-related deformities, are becoming increasingly prevalent due to both clinical conditions and lifestyle-related factors. Prolonged sedentary habits, such as sitting for extended hours in front of computers, as well as poor ergonomics in work and study environments, contribute significantly to the rise in musculoskeletal strain and chronic back pain. According to global health reports, spinal disorders rank among the leading causes of disability, imposing both personal and socioeconomic burdens. Early correction and continuous rehabilitation are therefore essential to prevent long-term complications. Conventional approaches to spinal rehabilitation include physiotherapy, rigid braces, and in severe cases, surgical interventions. While physiotherapy remains a cornerstone of treatment, its success often depends on patient compliance and regular supervision by

professionals. Rigid braces, on the other hand, though effective in providing structural support, are often uncomfortable, limit natural movement, and may cause reduced compliance over prolonged periods of use. Surgical intervention, while sometimes unavoidable, carries risks, high costs, and extended recovery times. These limitations highlight the need for innovative, non-invasive, and patient-friendly rehabilitation solutions. Wearable technology has

emerged as a promising field in biomedical engineering, offering opportunities to integrate real-time monitoring, feedback, and corrective mechanisms into comfortable, everyday devices. Among these innovations, posture-correcting and rehabilitation wearables have gained attention for their potential to enhance patient compliance and therapeutic outcomes. However, most existing devices either rely on rigid structures, lack continuous feedback mechanisms, or do not effectively balance comfort with corrective function. To address these challenges, this research focuses on the development of a smart spine rehabilitation vest. Designed with lightweight, breathable, and ergonomic materials, the vest incorporates embedded sensors that monitor spinal alignment and posture deviations while providing corrective biofeedback to the user. Unlike traditional braces, the vest emphasizes mobility, adaptability, and comfort, making it suitable for both clinical rehabilitation and preventive use in daily life. By enabling continuous monitoring and immediate feedback, the proposed vest encourages active participation from users in maintaining correct posture and supporting

long-term spinal health. This study aims to contribute to the growing field of assistive rehabilitation technologies by presenting a practical, non-invasive, and patient-centered solution for spinal care

2. Literature Survey

2.1 A passive spine-assist exoskeleton was designed using a segmented, elastic backbone structure to mimic human lumbar motion. The system supported natural flexion and extension through mechanical linkages and adjustable stiffness elements. Ergonomic analysis guided the design for multi-posture adaptability in occupational tasks. The device was tested on subjects performing lifting and prolonged bending, “Development of a Passive Back Support Exoskeleton Mimicking Human Spine Motion for Multi Posture Assistance in Occupational Tasks”, *Biomimetics*, 2025.

2.2 A 3D-printed wearable device used pneumatic actuators to correct poor posture. Sensors monitored spinal alignment and triggered air inflation to realign the upper body automatically, “Development of an Automatic Air-Driven 3D-Printed Spinal Posture Corrector”, *Actuators*, July 2022.

2.3 Participants: 19 cyclists with chronic low back pain (CLBP) and 20 healthy non-cyclist athletes (ages 18–60). Tests: Forward bending and backward return movements analyzed using a 6-camera motion capture system. Data Collected: Lumbar spine and pelvic range of motion (ROM) measured, “The Relationship between Prolonged Sitting Position and Adaptive Alterations in Lumbar Spine and Pelvic Range of Motion in Cyclist with Chronic Low Back Pain”, *World Family Medicine Journal*, December 2020.

2.4 Muscle fatigue: Surface EMG recorded from internal oblique/transversus abdominis (IO/TrA) and multifidus (MF) muscles. Perceived discomfort: Borg CR-10 scale (lower back discomfort rating). EMG Processing: Median frequency changes (first and last 5 minutes) used to assess muscle fatigue, “Effects of Prolonged Sitting with Slumped Posture on Trunk Muscular Fatigue in Adolescents with and without Chronic Lower Back Pain”, *Medicina*, December 2020.

2.5 A flexible resistive bending sensor embedded along the lumbar spine estimated the radius of curvature (RoC) in real time, calibrated using motion capture. A microcontroller compared RoC with ergonomic thresholds. Unsafe curvature triggered a compression alert. Prolonged deviation activated microneedle-based therapeutic stimulation, followed by a passive support phase to maintain corrected posture, “Estimation of Radius of Curvature of Lumbar Spine Using Bending Sensor for Low Back Pain Prevention”, *Lecture Notes in Computer Science*, vol 9299, 2019.

2.6 The authors conducted a systematic review of studies addressing ergonomics in manual agricultural operations. The review categorized work into key domains such as hand tool design, manual material handling, postural assessment, and environmental factors. Data were gathered from peer-reviewed publications, ergonomics databases, and agricultural safety reports, with emphasis on identifying risk factors and mitigation strategies, “A Review on Ergonomics in Agriculture. Part I: Manual Operations”, *Applied Sciences*, 2020

3. Methodology

The smart spine rehabilitation vest was developed using a structured engineering design process, including conceptualization, hardware integration, testing, and iterative refinement. Designed for long-term wear, the vest features lightweight, breathable, and ergonomic materials with adjustable straps and reinforced stitching for stability and comfort. Internal compartments house sensors, a microcontroller, and a power unit without restricting

movement, making it suitable for clinical and home use. To monitor posture, flex sensors and accelerometers are aligned along the thoracic and lumbar regions to detect angular deviations and spinal misalignment. Pressure sensors track load distribution for comprehensive assessment. Sensor data is processed by a compact, low-power microcontroller. A closed-loop feedback system activates vibration motors when poor posture is detected, offering three intensity levels tailored to rehabilitation needs. The electronics are modular and energy-efficient, powered by a rechargeable lithium-ion battery. Shielding techniques reduce interference, and the circuitry is designed for simple assembly and maintenance. A minimal digital interface displays data via a mobile or computer application, enabling users and therapists to monitor progress. Prototype testing with volunteers assessed comfort, usability, and feedback responsiveness. Insights from testing led to design improvements, resulting in a reliable, patient-friendly vest that supports active, comfortable posture correction and rehabilitation.

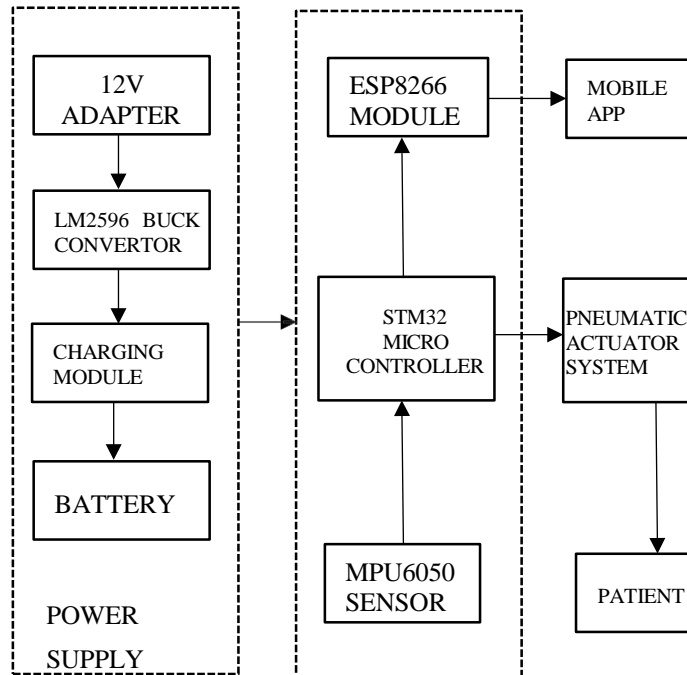

4. BLOCK DIAGRAM

5. HARDWARE SPECIFICATION

5.1 12V Adaptor

The 12V power adaptor is a crucial device that converts standard 100–240V AC input into a stable, regulated 12V DC output. It provides safe and reliable power for low-voltage electronic systems, safeguarding sensitive biomedical circuits from voltage fluctuations. Employing switching regulator technology, the adaptor ensures high efficiency, a compact form factor, and minimal heat production. Its current rating is chosen based on the needs of connected components such as microcontrollers, sensors, and actuators. In this project, the 12V adaptor serves as the primary power source, delivering continuous operation, compatibility, and user safety, making it well-suited for wearable biomedical devices.



Figure 1. 12V Adaptor

5.2 DC-DC Buck Converter (LM2596)

A DC-DC Buck Converter is a step-down voltage regulator that efficiently converts a greater DC input voltage to a steady, lower DC output value. The LM2596 is a popular monolithic integrated circuit for this application because to its high efficiency, small size, and ease of implementation. It operates at a set frequency of 150 kHz and uses a switching transistor and an inductor to reduce power loss, making it significantly more efficient than linear regulators. The LM2596 can provide up to 3A of load current and has adjustable or set output voltage options (often 3.3V, 5V, and 12V). It is widely used in embedded systems, battery-powered devices, and power supply modules to ensure stable voltage for microcontrollers, sensors, and communication modules while reducing heat generation and power wastage.



Figure 2. DC-DC Buck Converter (LM2596)

5.3 Battery

A battery is an electrochemical energy storage device that transforms chemical energy to electrical energy via redox processes. It comprises of one or more electrochemical cells, each with a positive electrode (cathode), a negative electrode (anode), and an electrolyte that allows ions to travel between electrodes. Batteries are classed into two types: primary (non - rechargeable) and secondary (rechargeable). Rechargeable batteries, such as lithium-ion, nickel-metal hydride, and lead- acid, are widely used in electronics, medical equipment, renewable energy systems, and electric vehicles because of their capacity to store and supply significant power multiple times. Voltage, capacity (mAh or Ah), energy density, cycle life, and discharge rate are key criteria that define a battery's suitability for a certain application. In biomedical or embedded systems, tiny, high -energy-density batteries provide dependable power for sensors, wearable devices, and portable medical tools, providing consistent performance and safety.



Figure 3. Battery

5.4 Micro-Controller STM32F103C8T6

The STM32F103C8T6 is STMicroelectronics' high- performance 32-bit microcontroller based on the ARM Cortex-M3 core. It operates at a clock frequency of up to 72 MHz and provides a good blend of processing power, low power consumption, and a wide range of peripherals, making it excellent for embedded systems. It includes 64 KB of Flash memory and 20 KB of SRAM for efficient program and data storage. The microcontroller supports multiple communication interfaces, including as USART, SPI, I²C, CAN, and USB, ensuring strong connectivity. It also has numerous 12-bit ADC channels, timers, and PWM outputs, making it ideal for motor control, sensor interface, and real- time data collecting. It is housed in a 48-pin LQFP device and runs between 2.0V and 3.6V, with various clock sources and power modes for energy economy. Its popularity arises from its inexpensive cost, open-source support, and ease of prototyping with the "Blue Pill" development board, which makes it frequently used in robotics, IoT devices, industrial automation, and biomedical equipment.



Figure 4. Micro-Controller STM32F103C8T6

5.5 MPU6050 Sensor

The MPU6050 is a highly integrated MEMS (Micro-Electro- Mechanical Systems) sensor module that includes a 3-axis gyroscope and a 3-axis accelerometer on a single chip, allowing for precise motion tracking and orientation detection. It uses the I²C communication standard for easy interaction with microcontrollers like Arduino and STM32. The sensor measures both acceleration (g) and angular velocity (°/s), making it appropriate for a variety of applications including robots, drones, gesture recognition, motion tracking, and wearables. This 3V-5V device has exceptional sensitivity and adjustable ranges for the accelerometer ($\pm 2g$ to $\pm 16g$) and gyroscope ($\pm 250^\circ/s$ to $\pm 2000^\circ/s$). The MPU6050 also features a Digital Motion Processor (DMP), which enables onboard sensor fusion and reduces the microcontroller's computing load. Its compact size, low power consumption, and accuracy make it an excellent choice for embedded systems that require real-time motion and orientation detection.



Figure 5. MPU6050 Sensor

5.6 ESP8266(WIFI)

The ESP8266 is a low-cost, highly integrated Wi-Fi module designed by Espressif Systems that is commonly used to enable Internet access in embedded systems and IoT applications. It has a 32-bit Tensilica L106 microcontroller running at up to 80 MHz and a built-in TCP/IP stack, allowing devices to connect to Wi-Fi networks without the need for a second microcontroller. The module works at 3.0V-3.6V and supports both Station (STA) and Access Point (AP) modes, allowing for flexible network setups. It provides GPIO pins, UART, SPI, and I²C interfaces, making it adaptable for communicating with sensors, actuators, and other devices. Popular variants like the ESP-01 are compact and easy to integrate, while development boards like NodeMCU simplify prototyping with USB programming and expanded I/O. The ESP8266 is widely used in home automation, wearable tech, smart appliances, and biomedical IoT systems due to its affordability, low power consumption, and strong community support.



FIGURE 6. ESP8266(WIFI)

5.7 Display

A display module is an electronic output device used to visually present data, text, graphics, or system status in embedded systems and IoT applications. Common types include LCD (Liquid Crystal Display), OLED (Organic Light Emitting Diode), and TFT (Thin-Film Transistor) displays, each offering different resolutions, sizes, and power consumption characteristics. In embedded projects, compact displays such as 16x2 or 20x4 character LCDs are widely used for simple text output, while TFT and OLED screens provide richer, high-resolution graphical interfaces for advanced systems. Displays typically interface with microcontrollers through I²C, SPI, or parallel communication, making them easy to integrate with platforms like STM32, Arduino, and Raspberry Pi. They are essential for real-time data monitoring, menu navigation, debugging, and user interaction in applications ranging from biomedical devices and wearables to robotics and industrial automation. Low-power versions are often chosen for portable systems to optimize battery life.



Figure 7. Display

6. SOFTWARE SPECIFICATION

The software specification defines the tools, programming environments, and frameworks used to develop, test, and implement the embedded system for this project. It provides a clear description of the software platforms, libraries, and communication protocols that ensure the proper functioning of the hardware components. This specification plays a critical role in system design as it guarantees compatibility between hardware and software while simplifying debugging, scaling, and feature integration. The primary development platform for the microcontroller, STM32F103C8T6, is the STM32CubeIDE provided by STMicroelectronics. This all-in-one environment integrates code editing, compilation, debugging, and flashing tools, allowing seamless software development in C and C++ programming languages. Additionally, the STM32CubeMX tool is employed to configure system clock settings, I/O pins, and communication peripherals (UART, SPI, I²C) via an intuitive graphical interface. These tools enhance development efficiency by automating code generation and reducing manual configuration errors. For sensor integration, such as the MPU6050 motion sensor, device-specific libraries and drivers are used to enable accurate data acquisition. The I²C communication protocol is implemented in firmware to ensure reliable data transfer between the microcontroller and the sensor module. Similarly, ESP8266 Wi-Fi module integration is supported using AT commands or the ESP8266 library, allowing real-time wireless data transmission to cloud platforms or mobile applications. Embedded firmware algorithms are written to process incoming sensor data, control actuators, and enable intelligent decision-making based on system feedback. To display information, software libraries compatible with LCD, OLED, or TFT displays are integrated into the firmware, ensuring smooth rendering of real-time system data. If a mobile or web-based application is part of the design, frameworks such as Blynk, MQTT, or Firebase are used to achieve secure IoT connectivity. Lightweight, open-source communication protocols enable efficient system control and monitoring over Wi-Fi networks. The software stack also includes debugging and simulation tools. STM32CubeIDE provides a built-in debugger that allows step-by-step code execution to identify logical or hardware-related issues. Additional serial communication tools like PuTTY or

Arduino Serial Monitor are employed to log and validate system data. For PCB and system simulation, Proteus Design Suite or Multisim may be used to test circuit functionality before hardware implementation. The system software is optimized for low power consumption, ensuring that the wearable or portable design conserves battery life while maintaining high performance. The modular firmware structure makes the system scalable, allowing for future integration of advanced features like machine learning or cloud-based analytics. Overall, this software specification ensures a robust, efficient, and maintainable embedded solution by integrating modern development tools, communication protocols, and libraries to achieve seamless interaction between sensors, microcontrollers, connectivity modules, and display units.

7. RESULTS AND DISCUSSION

1. Integration of advanced machine learning algorithms to analyze motion patterns, predict posture issues, and provide intelligent real-time corrective feedback.
2. Development of a dedicated cross-platform mobile and web application to enable enhanced user interaction, detailed data visualization, cloud storage, and remote health monitoring.
3. Addition of multiple biomedical sensors, such as heart rate, SpO₂, ECG, and temperature sensors, to create a more comprehensive health and wellness monitoring system.
4. Implementation of advanced power optimization techniques, energy harvesting, and next-generation battery technology to ensure longer operation without frequent charging.
5. Further miniaturization of hardware components and ergonomic redesigns to make the system more lightweight, comfortable, and suitable for long-term wearable use.
6. Integration of Bluetooth Low Energy (BLE), 5G, or LoRa connectivity options for improved communication speed, extended range, and IoT scalability.
7. Incorporation of customizable haptic feedback and adaptive pressure systems to offer more precise and comfortable therapeutic responses for different users.
8. Scaling the system for industrial, sports, rehabilitation, and medical applications, providing customization based on user needs, body type, and medical conditions.
9. Implementation of automated calibration and self-diagnostic systems to improve accuracy, reduce manual intervention, and ensure long-term reliability.
10. Development of AI-driven cloud analytics to store and analyze large datasets over time, providing personalized reports, progress tracking, and predictive recommendations for users and healthcare professionals.

8. CONCLUSION

This work presents a smart therapeutic wearable brace that integrates sensing, embedded processing, and wireless communication for real-time posture correction. The system effectively detects spinal misalignment and provides immediate haptic feedback to promote proper posture habits. Its ergonomic and lightweight design ensures user comfort, while wireless monitoring enables continuous rehabilitation assessment. The prototype demonstrated reliable performance, responsive feedback, and practical usability in daily-life conditions. The device offers a non-invasive and affordable solution for posture rehabilitation, especially beneficial for sedentary individuals and patients requiring long-term spinal care. Future improvements may include advanced analytics, miniaturized hardware, and expanded clinical validation to enhance its capabilities as a comprehensive rehabilitation system.

References

1. R. S. Gaikwad, P. A. Kulkarni, "Smart Wearable Device for Posture Monitoring and Correction," *International Journal of Innovative Research in Science, Engineering and Technology*, vol. 11, issue 4, pp. 5212-5217, April 2022.
2. M. H. Rahman, A. Hussain, "IoT Based Real-Time Posture Detection and Correction System," *International Journal of Scientific & Engineering Research*, vol. 13, issue 7, pp. 98-104, July 2022.
3. A. Mehmood, A. Ahmed, "Wearable Embedded System for Posture Correction with Feedback Mechanism," *International Journal of Electronics and Communication Engineering*, vol. 10, no. 3, pp. 187- 194, March 2021.
4. S. Banerjee, R. Mishra, "IoT-enabled Smart Health Monitoring System Using Wearable Sensors," *International Journal of Engineering Research & Technology*, vol. 9, issue 10, pp. 1-6, October 2020.



5. H. Sharma, V. S. Chouhan, "Posture Recognition and Correction System using Inertial Sensors," International Journal of Computer Applications, vol. 182, no. 43, pp. 25-31, January 2021.
6. K. Singh, M. S. Chauhan, "Design and Development of a Smart Therapeutic Wearable Vest," International Journal of Science and Research, vol. 9, issue 8, pp. 1302-1307, August 2020.
7. M. K. Gupta, "Smart IoT-based Wearable Device for Spine Health Monitoring," International Journal of Advanced Research in Computer Science, vol. 11, no. 6, pp. 1-6, June 2020.
8. J. Lee, Y. Kim, "IoT-based Wearable Posture Monitoring Device for Smart Healthcare," IEEE International Conference on Consumer Electronics (ICCE), pp. 1-4, January 2019.
9. R. S. Verma, "Development of Intelligent Wearable Devices for Physiotherapy Applications," International Journal of Biomedical Engineering and Technology, vol. 15, no. 4, pp. 365-373, 2021.
10. A.Kumar, "Next-Generation Wearable Systems for Health and Rehabilitation," Journal of Medical Engineering & Technology, vol. 44, no. 2, pp. 67-75, February 2020.